

22

Liquid Cooled Gas Engine Generator Sets

Standby Power Rating
22 kW 60 Hz



2.4L ENGINE

Naturally Aspirated
Gaseous Fueled

STANDARD EQUIPMENT

- All input connections in one single area
- High coolant temperature shutdown
- Low oil pressure shutdown
- Low coolant level automatic shutdown
- Overspeed automatic shutdown
- Crank timer
- Exercise timer
- Oil drain extension
- Cool flow radiator
- Closed coolant recovery system
- UV/Ozone resistant hoses
- Watertight state of the art electrical connectors
- Mainline circuit breaker
- Radiator drain extension
- Battery charge alternator
- 2 Amp static battery charger
- Battery cables
- Battery rack
- Fan and belt guards
- Isochronous governor
- Flex fuel line
- Hour meter

FEATURES

- Innovative design and fully prototype tested
- UL2200 Listed
- Solid state frequency compensated voltage regulator
- Dynamic and static battery charger
- Sound attenuated acoustically designed enclosure
- *Ultra Quiet Mode* for low noise level exercise
- Acoustically designed engine cooling system
- High flow low noise factory engineered exhaust system
- State of the art digital control system with R100 digital control panel
- Watertight electrical connectors
- Rodent proof construction
- High efficiency, low distortion alternator
- Vibration isolated from mounting base
- Matching transfer switches engineered and tested to work as a system
- All components easily accessible for maintenance
- Electrostatically applied powder paint

GENERATOR SPECIFICATIONS

TYPE	Synchronous
ROTOR INSULATION.....	Class H
STATOR INSULATION.....	Class H
TOTAL HARMONIC DISTORTION.....	<5%
TELEPHONE INTERFERENCE FACTOR (TIF)	<50
ALTERNATOR OUTPUT LEADS 3 PHASE	4 wire
BEARINGS.....	Sealed Ball
COUPLING.....	Flexible Disc
LOAD CAPACITY (STANDBY RATING).....	22 kW
EXCITATION SYSTEM.....	Direct

NOTE: Generator rating and performance in accordance with ISO8528-5, BS5514, SAE J1349, ISO3046, and DIN6271 standards.

VOLTAGE REGULATOR

TYPE	Electronic
SENSING	Single Phase
REGULATION.....	± 1%
FEATURES.....	V/F Adjustable Adjustable Voltage and Gain LED Indicators

GENERATOR FEATURES

- Revolving field heavy duty generator
- Directly connected to the engine
- Operating temperature rise 120 °C above a 40 °C ambient
- Insulation is Class H rated at 150 °C rise
- All models are fully prototyped tested

CONTROL PANEL FEATURES

- | | |
|--|--|
| <input type="checkbox"/> SEVEN LED INDICATOR LIGHTS | <input type="checkbox"/> ADDITIONAL FUNCTIONS |
| <ul style="list-style-type: none"> • System ready • Low fuel pressure • Low battery • Low oil pressure • High coolant temp/low coolant temp • Overspeed • Overcrank | <ul style="list-style-type: none"> • Utility sensing • Delay on utility failure for engine start • Engine warm-up before transfer • Delay to retransfer to utility • Engine cooldown timer • Exerciser not set • Hour meter |
| <input type="checkbox"/> INTERNAL FUNCTIONS: | |
| <ul style="list-style-type: none"> • 3 position switch (auto, off and manual) • 2 wire start for any transfer switch • Communicates with the KGAT transfer switch • Built-in 7 day exerciser • Selectable engine speed at exercise • Governor controller is built into the master control board • Temperature range -40 °C to 70 °C | |

ENGINE SPECIFICATIONS

MAKE	Generac
MODEL.....	Inline 4
CYLINDERS.....	4
DISPLACEMENT.....	2.4 Liter
BORE.....	3.41
STROKE.....	3.94
COMPRESSION RATIO.....	8.5:1
INTAKE AIR SYSTEM.....	Naturally Aspirated
VALVE SEATS.....	Hardened
LIFTER TYPE.....	Hydraulic

GOVERNOR SPECIFICATIONS

TYPE	Electronic
FREQUENCY REGULATION.....	Isochronous
STEADY STATE REGULATION.....	± 0.25
ADJUSTMENTS FOR:	
Speed	Yes
Droop.....	Yes

ENGINE LUBRICATION SYSTEM

OIL PUMP	Gear
OIL FILTER.....	Full flow spin-on cartridge
CRANKCASE CAPACITY.....	4 Quarts

ENGINE COOLING SYSTEM

TYPE	Closed
WATER PUMP.....	Belt driven
FAN SPEED	1980
FAN DIAMETER.....	17.75 inches
FAN MODE.....	Pusher

FUEL SYSTEM

FUEL TYPE.....	Natural gas, propane vapor
CARBURETOR.....	Down Draft
SECONDARY FUEL REGULATOR.....	Standard
FUEL SHUT OFF SOLENOID	Standard
OPERATING FUEL PRESSURE.....	5" - 14" H ₂ O

ELECTRICAL SYSTEM

BATTERY CHARGE ALTERNATOR.....	12V 30 Amp
STATIC BATTERY CHARGER	2 Amp
RECOMMENDED BATTERY	Group 26, 525CCA
SYSTEM VOLTAGE.....	12 Volts

OPERATING DATA

KW RATING	22		
ENGINE SIZE	2.4 Liter Inline 4		
GENERATOR OUTPUT VOLTAGE/KW - 60Hz 120/240V, 1-phase, 1.0 pf	KW 22	AMP 92	CB Size 100
GENERATOR LOCKED ROTOR KVA AVAILABLE @ VOLTAGE DIP OF 35% Single phase	43		
ENGINE FUEL CONSUMPTION (Natural Gas) (Propane)	Natural Gas (ft ³ /hr.)	Propane (gal/hr.) cu ft/hr	
Exercise cycle	42	0.44	16
25% of rated load	100	1.0	38
50% of rated load	190	2.0	72
75% of rated load	255	2.7	98
100% of rated load	316	3.3	120
ENGINE COOLING			
Air flow (inlet air including alternator and combustion air)	ft ³ /min.	2,400	
System coolant capacity	US gal.	2.5	
Heat rejection to coolant	BTU/hr.	99,000	
Max. operating air temp. on radiator	°C (°F)	60 (150)	
Max. ambient temperature	°C (°F)	50 (140)	
COMBUSTION AIR REQUIREMENTS			
Flow at rated power 60 Hz	cfm	68	
SOUND EMISSIONS IN DBA			
Exercising at 7 meters	61		
Normal operation at 7 meters	70		
EXHAUST			
Exhaust flow at rated output 60 Hz	cfm	165	
Exhaust temp. at muffler outlet	°F	900	
ENGINE PARAMETERS			
Rated synchronous RPM	60 Hz	1800	
HP at rated KW	60 Hz	40	
POWER ADJUSTMENT FOR AMBIENT CONDITIONS			
Temperature Deration			
3% for every 10 °C above - °C	25		
1.65% for every 10 °F above - °F	77		
Altitude Deration			
1% for every 100 m above - m	183		
3% for every 1000 ft. above - ft.	600		
ENCLOSURE			
Material	Aluminum		

RATING: All three phases units are rated at 0.8 power factor. All single phase units are rated at 1.0 power factor. STANDBY RATING: Standby ratings apply to installations served by a reliable utility source. The standby rating is applicable to varying loads for the duration of a power outage. There is no overload capability for this rating. Ratings are in accordance with ISO-3046-1. Design and specifications are subject to change without notice.

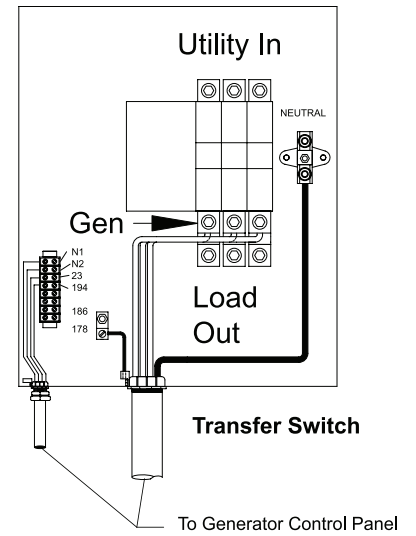
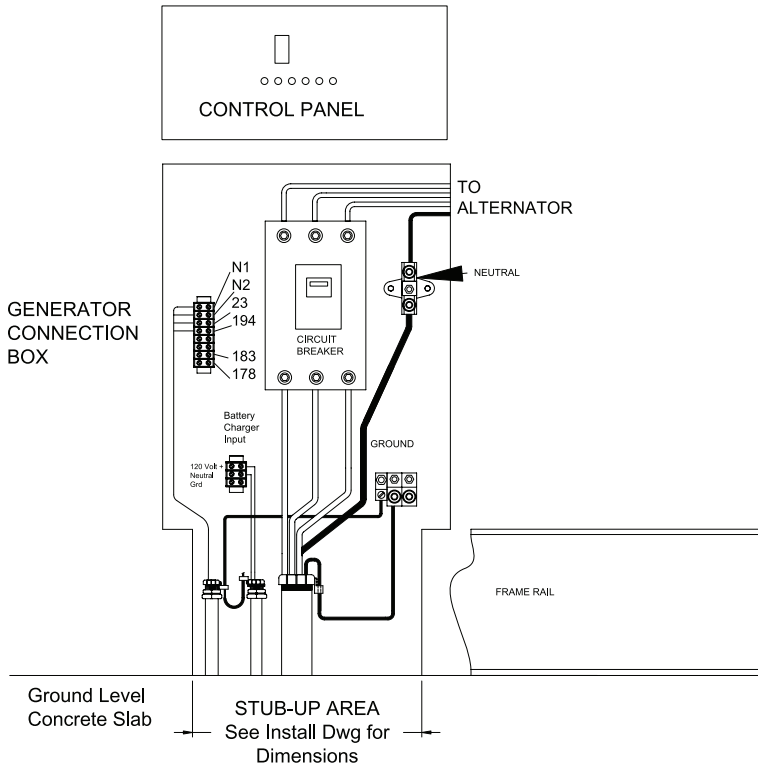

CIRCUIT BREAKER SIZE			
KW	VOLTS	/ AMPS	LUG SIZE
22	240 1 Ø	100	#6 to 2/0

Installation Drawing Ref. No. 0G0325

INSTALLATION LAYOUT

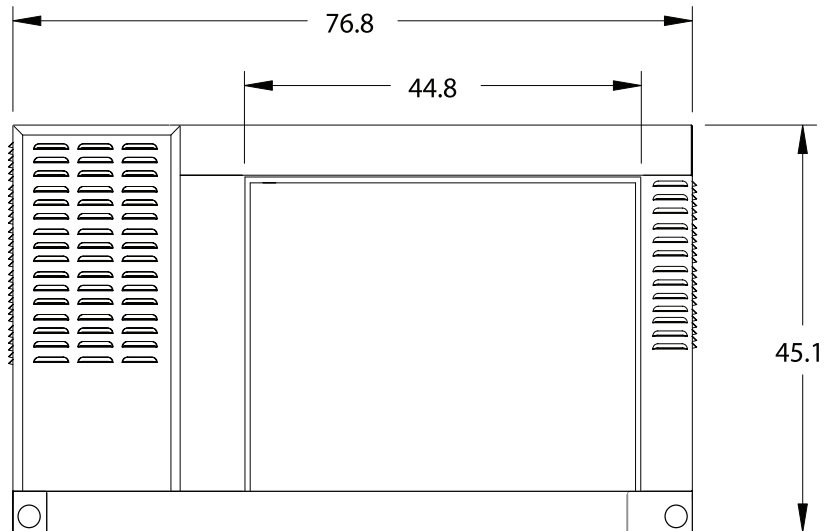
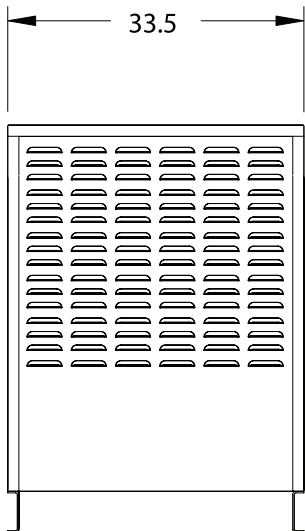

WEIGHT: 843 lbs.