

# 27

## Liquid Cooled Gas Engine Generator Sets

Standby Power Rating  
**27 kW 60 Hz**



**2.4L ENGINE**

Naturally Aspirated  
Gaseous Fueled

### STANDARD EQUIPMENT

- All input connections in one single area
- High coolant temperature shutdown
- Low oil pressure shutdown
- Low coolant level automatic shutdown
- Overspeed automatic shutdown
- Crank timer
- Exercise timer
- Oil drain extension
- Cool flow radiator
- Closed coolant recovery system
- UV/Ozone resistant hoses
- Watertight state of the art electrical connectors
- Mainline circuit breaker
- Radiator drain extension
- Battery charge alternator
- 2 Amp static battery charger
- Battery cables
- Battery rack
- Fan and belt guards
- Isochronous governor
- Flex fuel line
- Hour meter

### FEATURES

- Innovative design and fully prototype tested
- UL2200 Listed
- Solid state frequency compensated voltage regulator
- Dynamic and static battery charger
- Sound attenuated acoustically designed enclosure
- *Ultra Quiet Mode* for low noise level exercise
- Acoustically designed engine cooling system
- High flow low noise factory engineered exhaust system
- State of the art digital control system with R100 digital control panel
- Watertight electrical connectors
- Rodent proof construction
- High efficiency, low distortion alternator
- Vibration isolated from mounting base
- Matching transfer switches engineered and tested to work as a system
- All components easily accessible for maintenance
- Electrostatically applied powder paint

## GENERATOR SPECIFICATIONS

TYPE .....	Synchronous
ROTOR INSULATION.....	Class H
STATOR INSULATION.....	Class H
TOTAL HARMONIC DISTORTION.....	<5%
TELEPHONE INTERFERENCE FACTOR (TIF) .....	<50
ALTERNATOR OUTPUT LEADS 3 PHASE .....	4 wire
BEARINGS.....	Sealed Ball
COUPLING.....	Flexible Disc
LOAD CAPACITY (STANDBY RATING).....	27 kW
EXCITATION SYSTEM.....	Direct

**NOTE:** Generator rating and performance in accordance with ISO8528-5, BS5514, SAE J1349, ISO3046, and DIN6271 standards.

## VOLTAGE REGULATOR

TYPE .....	Electronic
SENSING .....	Single Phase
REGULATION.....	± 1%
FEATURES.....	V/F Adjustable Adjustable Voltage and Gain LED Indicators

## GENERATOR FEATURES

- Revolving field heavy duty generator
- Directly connected to the engine
- Operating temperature rise 120 °C above a 40 °C ambient
- Insulation is Class H rated at 150 °C rise
- All models are fully prototyped tested

## CONTROL PANEL FEATURES

- SEVEN LED INDICATOR LIGHTS
  - System ready
  - Low fuel pressure
  - Low battery
  - Low oil pressure
  - High coolant temp/low coolant temp
  - Overspeed
  - Overcrank
- INTERNAL FUNCTIONS:
  - 3 position switch (auto, off and manual)
  - 2 wire start for any transfer switch
  - Communicates with the KGAT transfer switch
  - Built-in 7 day exerciser
  - Selectable engine speed at exercise
  - Governor controller is built into the master control board
  - Temperature range -40 °C to 70 °C
- ADDITIONAL FUNCTIONS
  - Utility sensing
  - Delay on utility failure for engine start
  - Engine warm-up before transfer
  - Delay to retransfer to utility
  - Engine cooldown timer
  - Exerciser not set
  - Hour meter

## ENGINE SPECIFICATIONS

MAKE .....	Generac
MODEL.....	Inline 4
CYLINDERS.....	4
DISPLACEMENT.....	2.4 Liter
BORE.....	3.41
STROKE.....	3.94
COMPRESSION RATIO.....	8.5:1
INTAKE AIR SYSTEM.....	Naturally Aspirated
VALVE SEATS.....	Hardened
LIFTER TYPE.....	Hydraulic

## GOVERNOR SPECIFICATIONS

TYPE .....	Electronic
FREQUENCY REGULATION.....	Isochronous
STEADY STATE REGULATION.....	± 0.25
ADJUSTMENTS FOR:	
Speed .....	Yes
Droop.....	Yes

## ENGINE LUBRICATION SYSTEM

OIL PUMP .....	Gear
OIL FILTER.....	Full flow spin-on cartridge
CRANKCASE CAPACITY.....	4 Quarts

## ENGINE COOLING SYSTEM

TYPE .....	Closed
WATER PUMP.....	Belt driven
FAN SPEED .....	1980
FAN DIAMETER.....	17.75 inches
FAN MODE.....	Pusher

## FUEL SYSTEM

FUEL TYPE.....	Natural gas, propane vapor
CARBURETOR.....	Down Draft
SECONDARY FUEL REGULATOR.....	Standard
FUEL SHUT OFF SOLENOID .....	Standard
OPERATING FUEL PRESSURE.....	5" - 14" H <sub>2</sub> O

## ELECTRICAL SYSTEM

BATTERY CHARGE ALTERNATOR.....	12V 30 Amp
STATIC BATTERY CHARGER .....	2 Amp
RECOMMENDED BATTERY .....	Group 26, 525CCA
SYSTEM VOLTAGE.....	12 Volts

## OPERATING DATA

<b>KW RATING</b>	27				
<b>ENGINE SIZE</b>	2.4 Liter Inline 4				
<b>GENERATOR OUTPUT VOLTAGE/KW - 60Hz</b> 120/240V, 1-phase, 1.0 pf	<b>KW Nat. Gas</b> 25	<b>AMP</b> 104	<b>KW LPG</b> 27	<b>AMP</b> 112	<b>CB Size (Both)</b> 125
<b>GENERATOR LOCKED ROTOR KVA AVAILABLE @ VOLTAGE DIP OF 35%</b> Single phase	43				
<b>ENGINE FUEL CONSUMPTION (Natural Gas) (Propane)</b>	<b>Natural Gas (25 kW)</b>		<b>Propane (27 kW)</b>		
	(ft <sup>3</sup> /hr.)		(gal/hr.)		cu ft/hr
Exercise cycle	42		0.44		16
25% of rated load	108		1.2		44
50% of rated load	197		2.2		81
75% of rated load	287		3.2		118
100% of rated load	359		4.1		147
<b>ENGINE COOLING</b>					
Air flow (inlet air including alternator and combustion air)	ft <sup>3</sup> /min.		2,400		
System coolant capacity	US gal.		2.5		
Heat rejection to coolant	BTU/hr.		120,000		
Max. operating air temp. on radiator	°C (°F)		60 (150)		
Max. ambient temperature	°C (°F)		50 (140)		
<b>COMBUSTION AIR REQUIREMENTS</b>					
Flow at rated power 60 Hz	cfm		68		
<b>SOUND EMISSIONS IN DBA</b>					
Exercising at 7 meters			62		
Normal operation at 7 meters			75		
<b>EXHAUST</b>					
Exhaust flow at rated output 60 Hz	cfm		130		
Exhaust temp. at muffler outlet	°F		900		
<b>ENGINE PARAMETERS</b>					
Rated synchronous RPM	60 Hz		1800		
HP at rated KW	60 Hz		40		
<b>POWER ADJUSTMENT FOR AMBIENT CONDITIONS</b>					
Temperature Deration					
3% for every 10 °C above - °C			25		
1.65% for every 10 °F above - °F			77		
Altitude Deration					
1% for every 100 m above - m			183		
3% for every 1000 ft. above - ft.			600		
<b>ENCLOSURE</b>					
Material	Aluminum				

RATING: All three phases units are rated at 0.8 power factor. All single phase units are rated at 1.0 power factor. STANDBY RATING: Standby ratings apply to installations served by a reliable utility source. The standby rating is applicable to varying loads for the duration of a power outage. There is no overload capability for this rating. Ratings are in accordance with ISO-3046-1. Design and specifications are subject to change without notice.

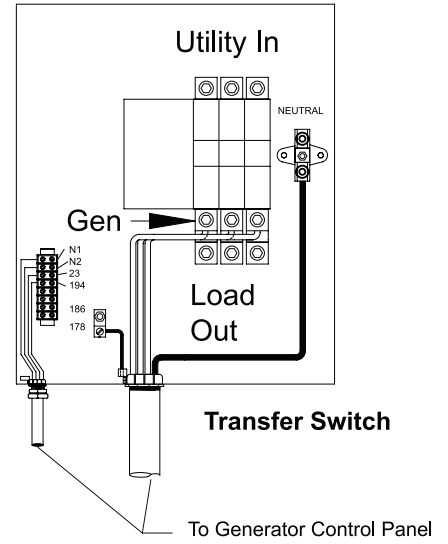
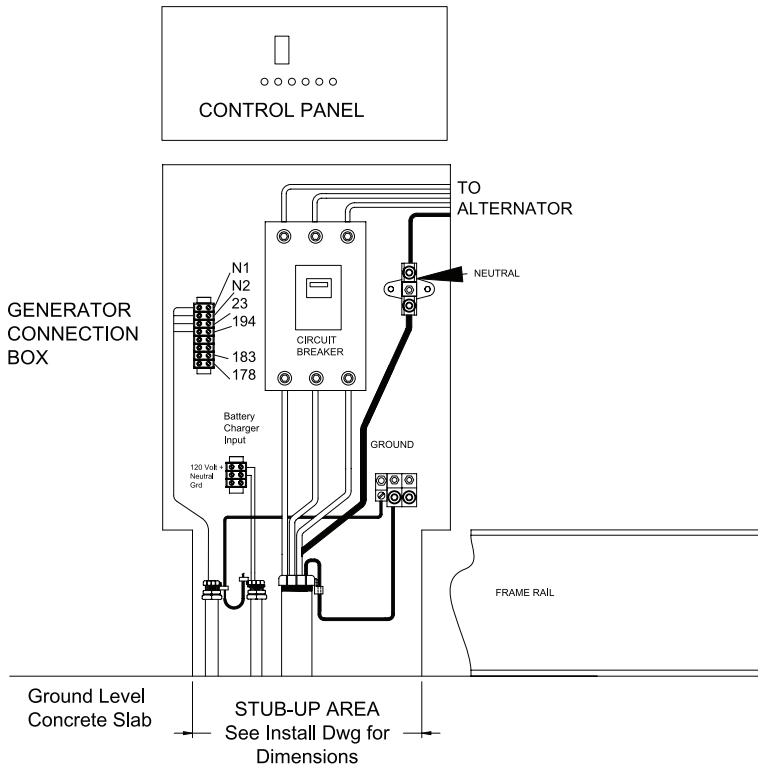

CIRCUIT BREAKER SIZE			
KW	VOLTS	AMPS	LUG SIZE
27	240 1 Ø	125	#2 to 1/0

Installation Drawing Ref. No. 0G0325

# INSTALLATION LAYOUT

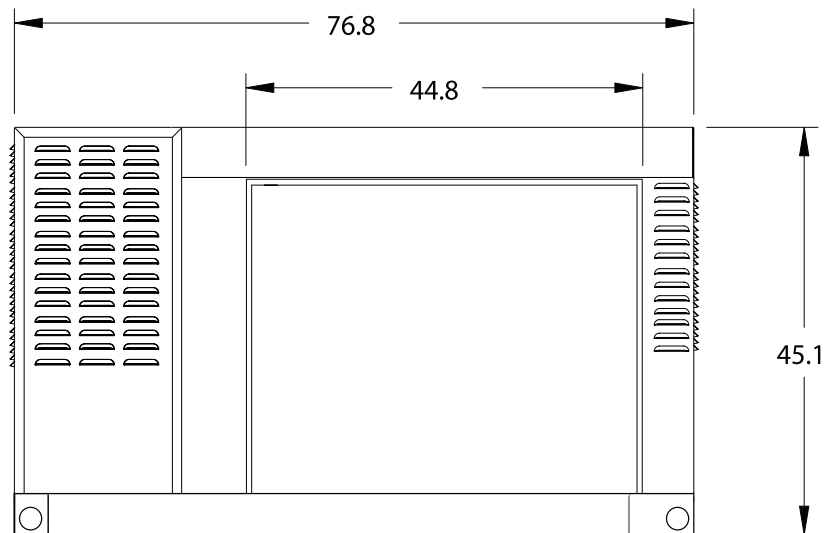
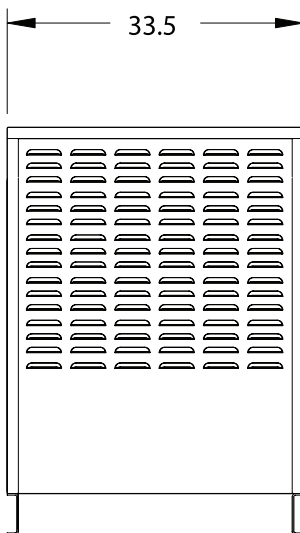

**WEIGHT: 891 lbs.**