

36

Liquid Cooled Gas Engine Generator Sets

Standby Power Rating
36 kW 60 Hz



2.4L ENGINE

Turbcharged/Aftercooled
Gaseous Fueled

STANDARD EQUIPMENT

- All input connections in one single area
- High coolant temperature shutdown
- Low oil pressure shutdown
- Low coolant level automatic shutdown
- Overspeed automatic shutdown
- Crank timer
- Exercise timer
- Oil drain extension
- Cool flow radiator
- Closed coolant recovery system
- UV/Ozone resistant hoses
- Watertight state of the art electrical connectors
- Mainline circuit breaker
- Radiator drain extension
- Battery charge alternator
- 2 Amp static battery charger
- Battery cables
- Battery rack
- Fan and belt guards
- Isochronous governor
- Flex fuel line
- Hour meter

FEATURES

- Innovative design and fully prototype tested
- UL2200 Listed
- Solid state frequency compensated voltage regulator
- Dynamic and static battery charger
- Sound attenuated acoustically designed enclosure
- *Ultra Quiet Mode* for low noise level exercise
- Acoustically designed engine cooling system
- High flow low noise factory engineered exhaust system
- State of the art digital control system with R100 digital control panel
- Watertight electrical connectors
- Rodent proof construction
- High efficiency, low distortion alternator
- Vibration isolated from mounting base
- Matching transfer switches engineered and tested to work as a system
- All components easily accessible for maintenance
- Electrostatically applied powder paint

GENERATOR SPECIFICATIONS

TYPE	Synchronous
ROTOR INSULATION.....	Class H
STATOR INSULATION.....	Class H
TOTAL HARMONIC DISTORTION.....	<5%
TELEPHONE INTERFERENCE FACTOR (TIF)	<50
ALTERNATOR OUTPUT LEADS 3 PHASE	4 wire
BEARINGS.....	Sealed Ball
COUPLING.....	Flexible Disc
LOAD CAPACITY (STANDBY RATING).....	36 kW
EXCITATION SYSTEM.....	Direct

NOTE: Generator rating and performance in accordance with ISO8528-5, BS5514, SAE J1349, ISO3046, and DIN6271 standards.

VOLTAGE REGULATOR

TYPE	Electronic
SENSING	Single Phase
REGULATION.....	± 1%
FEATURES.....	V/F Adjustable Adjustable Voltage and Gain LED Indicators

GENERATOR FEATURES

- Revolving field heavy duty generator
- Directly connected to the engine
- Operating temperature rise 120 °C above a 40 °C ambient
- Insulation is Class H rated at 150 °C rise
- All models are fully prototyped tested

CONTROL PANEL FEATURES

- | | |
|---|---|
| <ul style="list-style-type: none"> <input type="checkbox"/> SEVEN LED INDICATOR LIGHTS <ul style="list-style-type: none"> • System ready • Low fuel pressure • Low battery • Low oil pressure • High coolant temp/low coolant temp • Overspeed • Overcrank <input type="checkbox"/> INTERNAL FUNCTIONS: <ul style="list-style-type: none"> • 3 position switch (auto, off and manual) • 2 wire start for any transfer switch • Communicates with the KGAT transfer switch • Built-in 7 day exerciser • Selectable engine speed at exercise • Governor controller is built into the master control board • Temperature range -40 °C to 70 °C | <ul style="list-style-type: none"> <input type="checkbox"/> ADDITIONAL FUNCTIONS <ul style="list-style-type: none"> • Utility sensing • Delay on utility failure for engine start • Engine warm-up before transfer • Delay to retransfer to utility • Engine cooldown timer • Exerciser not set • Hour meter |
|---|---|

ENGINE SPECIFICATIONS

MAKE	Generac
MODEL.....	Inline 4
CYLINDERS.....	4
DISPLACEMENT.....	2.4 Liter
BORE (inches)	3.41
STROKE (inches).....	3.94
COMPRESSION RATIO.....	8.5:1
INTAKE AIR SYSTEM.....	Turbocharged/Aftercooled
VALVE SEATS	Hardened
LIFTER TYPE.....	Hydraulic

GOVERNOR SPECIFICATIONS

TYPE	Electronic
FREQUENCY REGULATION.....	Isochronous
STEADY STATE REGULATION.....	± 0.25
ADJUSTMENTS FOR:	
Speed	Yes
Droop.....	Yes

ENGINE LUBRICATION SYSTEM

OIL PUMP	Gear
OIL FILTER.....	Full flow spin-on cartridge
CRANKCASE CAPACITY.....	4 Quarts

ENGINE COOLING SYSTEM

TYPE	Closed
WATER PUMP.....	Belt driven
FAN SPEED	1050
FAN DIAMETER.....	22 inches
FAN MODE.....	Puller

FUEL SYSTEM

FUEL TYPE.....	Natural gas, propane vapor
CARBURETOR.....	Down Draft
SECONDARY FUEL REGULATOR.....	Standard
FUEL SHUT OFF SOLENOID	Standard
OPERATING FUEL PRESSURE.....	5" - 14" H ₂ O

ELECTRICAL SYSTEM

BATTERY CHARGE ALTERNATOR.....	12V 30 Amp
STATIC BATTERY CHARGER	2 Amp
RECOMMENDED BATTERY	Group 26, 525CCA
SYSTEM VOLTAGE.....	12 Volts

OPERATING DATA

KW RATING	36/35				
ENGINE SIZE	2.4 Liter				
GENERATOR OUTPUT VOLTAGE/KW - 60Hz 120/240V, 1-phase, 1.0 pf	kW - LP 36	Amps 150	KW - NG 35	Amps 146	CB Size 175
GENERATOR LOCKED ROTOR KVA AVAILABLE @ VOLTAGE DIP OF 35% Single phase	63				
ENGINE FUEL CONSUMPTION (Natural Gas) (Propane)	Natural Gas (ft ³ /hr.)		Propane (gal/hr.) cu ft/hr		
Exercise cycle	87		0.96		
25% of rated load	156		1.67		
50% of rated load	282		3.0		
75% of rated load	392		4.2		
100% of rated load	503		5.4		
ENGINE COOLING					
Air flow (inlet air including alternator and combustion air)	ft ³ /min.		2,200		
System coolant capacity	US gal.		2.5		
Heat rejection to coolant	BTU/hr.		135,000		
Max. operating air temp. on radiator	°C (°F)		60 (150)		
Max. ambient temperature	°C (°F)		50 (140)		
COMBUSTION AIR REQUIREMENTS					
Flow at rated power 60 Hz	cfm		106		
SOUND EMISSIONS IN DBA					
Exercising at 7 meters			58		
Normal operation at 7 meters			64		
EXHAUST					
Exhaust flow at rated output 60 Hz	cfm		300		
Exhaust temp. at muffler outlet	°F		1075		
ENGINE PARAMETERS					
Rated synchronous RPM	60 Hz		1800		
HP at rated KW	60 Hz		56		
POWER ADJUSTMENT FOR AMBIENT CONDITIONS					
Temperature Deration					
3% for every 10 °C above - °C			25		
1.65% for every 10 °F above - °F			77		
Altitude Deration					
1% for every 100 m above - m			915		
3% for every 1000 ft. above - ft.			3000		

RATING: All three phase units are rated at 0.8 power factor. All single phase units are rated at 1.0 power factor. STANDBY RATING: Standby ratings apply to installations served by a reliable utility source. The standby rating is applicable to varying loads for the duration of a power outage. There is no overload capability for this rating. Ratings are in accordance with ISO-3046-1. Design and specifications are subject to change without notice. KW rating is based on LPG Fuel and may derate with natural gas.

INTERCONNECTIONS

QT036

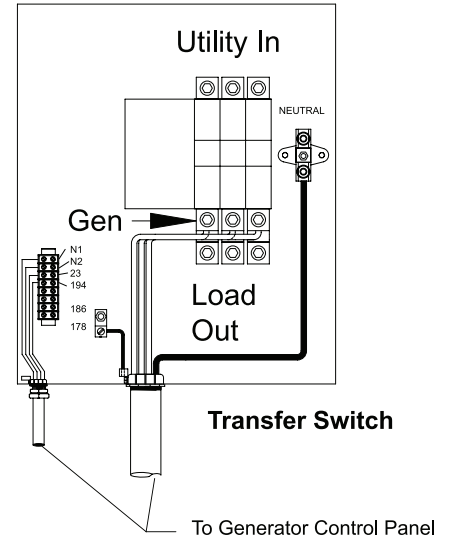
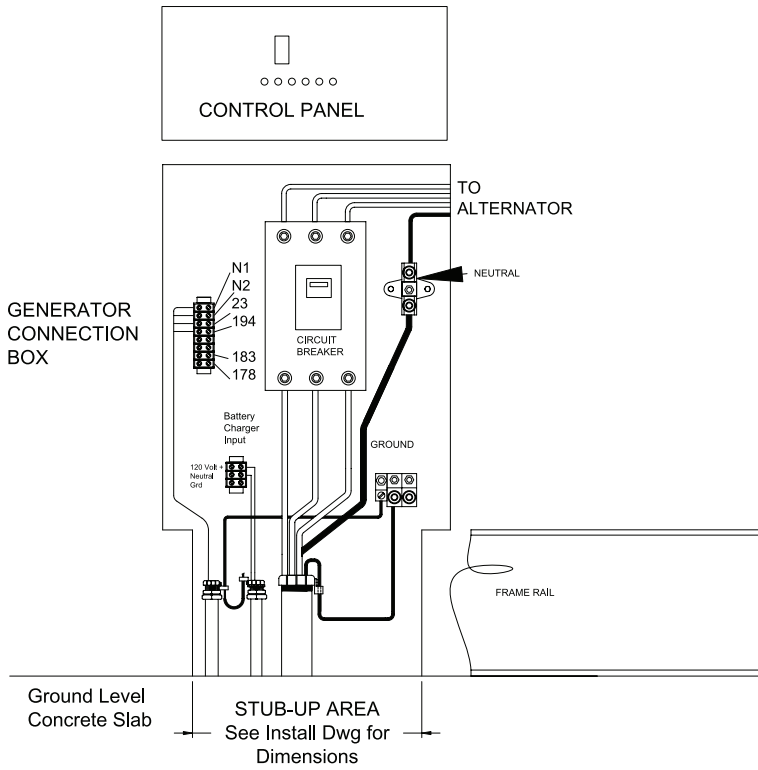

CIRCUIT BREAKER SIZE

kW	VOLTS	AMPS	LUG SIZE
36	240 1ø	175	#6 to 300 MCM

Installation Drawing Ref. No. 0F6286

INSTALLATION LAYOUT

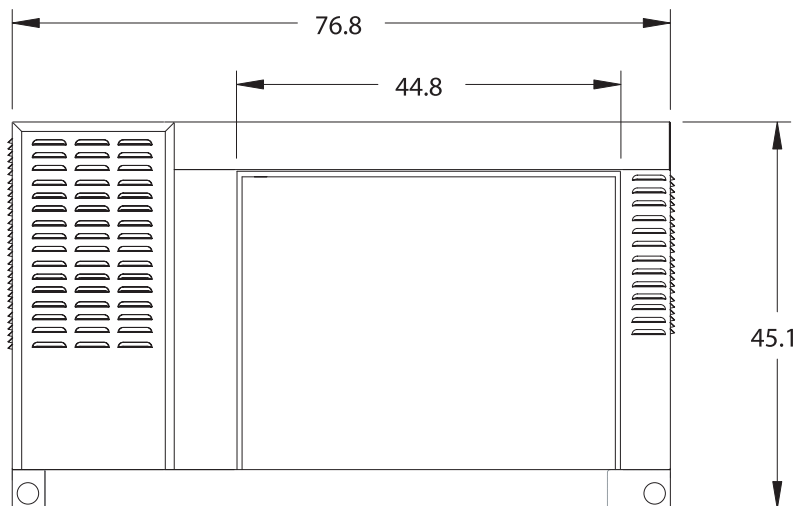
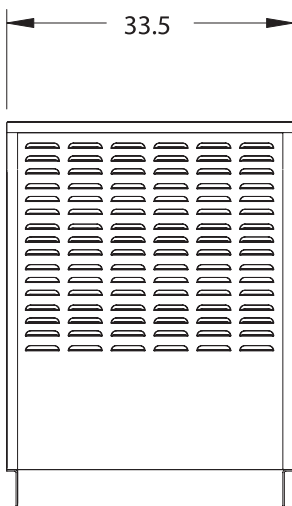

WEIGHT: 1,512 lbs.